

※NOTES※

MECHANICAL

- ① HOUSING : THERMOPLASTIC-LCP, UL94V-0, BLACK
- ② CONTACT : COPPER ALLOY
- ③ SHIELD : STAINLESS STEEL, T=0.12mm
- ④ SHELL : STAINLESS STEEL, T=0.30mm

SPECIFICATION

- ① CURRENT RATING : 5 AMPHERES FOR VBUS
1.25 AMPHERES FOR GND PIN
0.25 AMPERE FOR OTHER PINS.
- ② VOLTAGE RATING : 20V MAX.
- ③ WITHSTANDING VOLTAGE : 100V AC R.M.S.
- ④ CONTACT RESISTANCE : 40 MILLIOHMS MAX.
- ⑤ INSULATION RESISTANCE : 100 MEGOHMS MIN.
- ⑥ MATING FORCE : 5N~20N MAX.
- ⑦ UNMATING FORCE : 8N~20N MAX.
- ⑧ DURABILITY : 10,000 CYCLES MIN.
- ⑨ TEMPERATURE RANGE : -55°C ~ +85°C

ORDER OPTION

RUCH1- 1 * * R024C3

PLATING
0~Au 0.2~1μ D.C.A.
4~Au 15μ D.C.A.
6~Au 30μ D.C.A.
(DCA=DN CONTACT AREA)

HOUSING
1~BLACK
2~BEIGE
A~BLUE

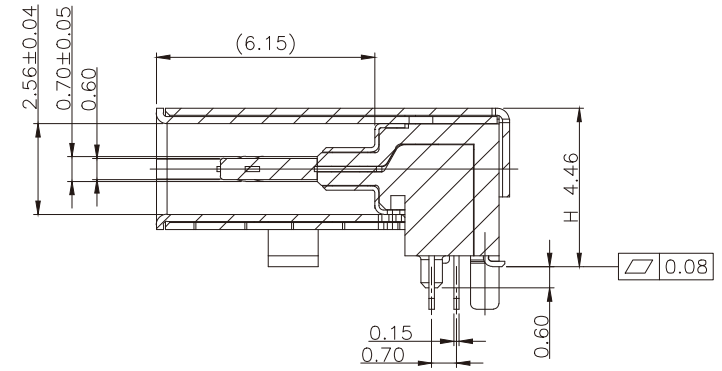
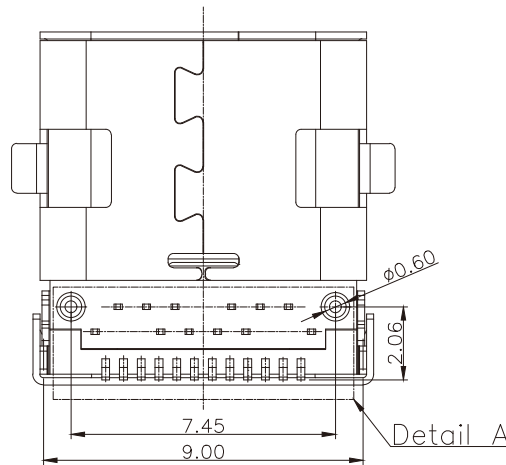
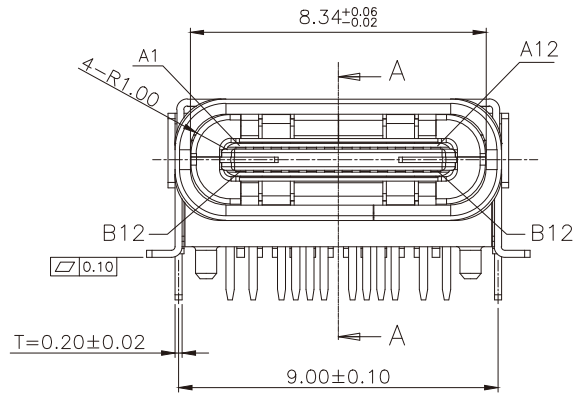
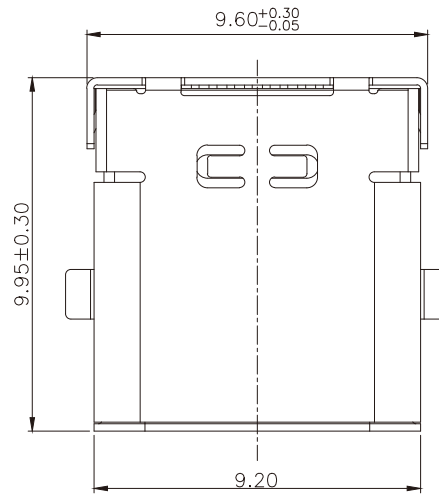
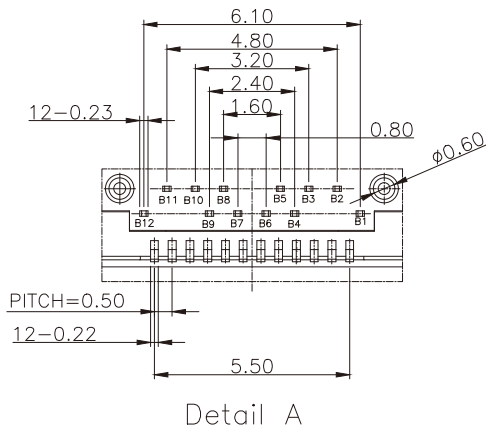

A-A
SCALE 1:1

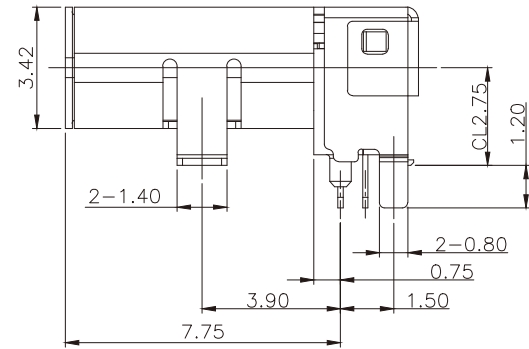

METRIC		WIROS Electronics Int'l CO., Ltd.
DRAWER ZHUANG APPROVER ALEX, WU	NOTICE OF PROPRIETARY PROPERTY: THIS DRAWING CONTAINS INFORMATION THAT IS PROPRIETARY TO WIROS ELECTRONICS INTERNATIONAL COMPANY LIMITED. AND SHOULD NOT BE USED WITHOUT WIROS'S WRITTEN CONSENT.	
DIMENSIONS ARE IN MILLIMETERS TOLERANCES X. ±0.50 X.X ±0.38 X.XX ±0.25 X.XXX ±0.10 ANGLES ±3°	TITLE USB 3.1 TYPE C 12P THT AND 12P SMT H=4.46mm, RECEPTACLE CONNECTOR	
DO NOT SCALE DRAWINGS 	PRODUCT NUMBER RUCH1-1* *R024C3	
SIZE A4	REV.	SCALE 1 : 1 SHEET 1 OF 4

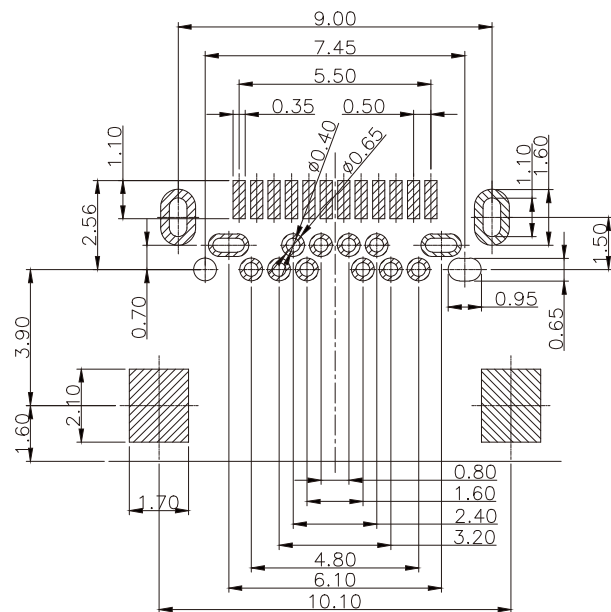
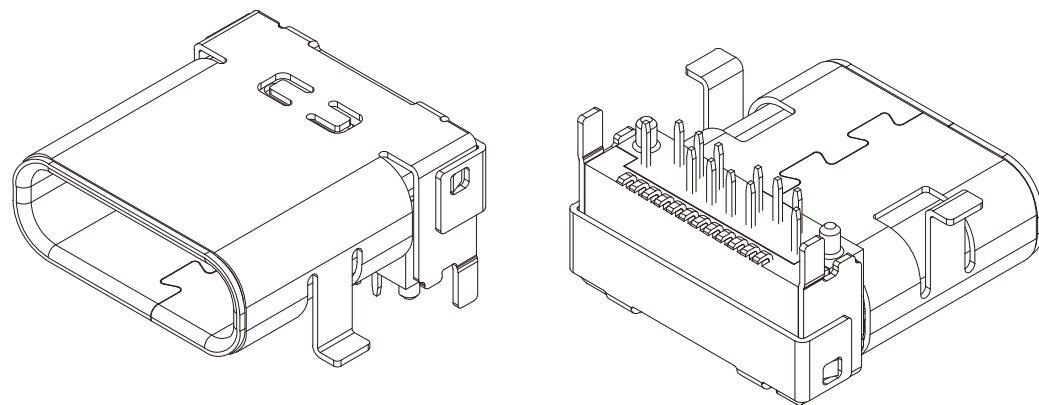

RECOMMEND PCB LAYOUT (COMPONENT SIDE)

KEEP OUT AREA

USB TYPE-C FULL-FEATURED RECEPTACLE INTERFACE PIN ASSIGNMENTS

PIN	Signal Name	Description	PIN	Signal Name	Description
A1	GND	Ground return	B12	GND	Ground return
A2	SSTXp1	Positive half of first SuperSpeed TX differential pair	B11	SSRXp1	Positive half of first SuperSpeedRX differential pair
A3	SSTXn1	Negative half of first SuperSpeed TX differential pair	B10	SSRXn1	Negative half of first SuperSpeedRX differential pair
A4	VBUS	Bus Power	B9	VBUS	Bus Power
A5	CC1	Configuration Channel	B8	SBU2	Sideband Use (SBU)
A6	Dp1	Positive half of the USB 2.0 differential pair-Position 1	B7	Dn2	Negative half of the USB 2.0 differential pair-Position 2
A7	Dn1	Negative half of the USB 2.0 differential pair-Position 1	B6	Dp2	Positive half of the USB 2.0 differential pair-Position 2
A8	SBU1	Sideband Use(SBU)	B5	CC2	Configuraation Channel
A9	VBUS	Bus Power	B4	VBUS	Bus Power
A10	SSRXn2	Negative half of second SuperSpeed RX differential pair	B3	SSTXn2	Negative half of second SuperSpeed TX differential pair
A11	SSRXp2	Positive half of second SuperSpeed RX differential pair	B2	SSTXp2	Positive half of second SuperSpeed TX differential pair
A12	GND	Ground return	B1	GND	Ground return

QUALITY CONTROL LINE DIMENSIONS SHALL PRECED THE SYMBOL, IF THE SYMBOL IS PRESENT RoHS COMPLIANT HTP THIRD ANGLE PROJECTION LEAD FREE	METRIC	WIROS Electronics Int'l CO., Ltd.	
	DRAWER ZHUANG APPROVER ALEX, WU	NOTICE OF PROPRIETARY PROPERTY: THIS DRAWING CONTAINS INFORMATION THAT IS PROPRIETARY TO WIROS ELECTRONICS INTERNATIONAL COMPANY LIMITED AND SHOULD NOT BE USED WITHOUT WIROS'S WRITTEN CONSENT.	
	DIMENSIONS ARE IN MILLIMETERS TOLERANCES X. ±0.50 X.X ±0.38 X.XX ±0.25 X.XXX ±0.10 ANGLES ±3°	TITLE USB 3.1 TYPE C 12P THT AND 12P SMT H=4.46mm, RECEPTACLE CONNECTOR	
	DO NOT SCALE DRAWINGS THIRD ANGLE PROJECTION	PRODUCT NUMBER RUCH1-1X×R024C3	SCALE 1 : 1
SIZE A4	REV.	SHEET 2 OF 4	

NOTES

1. 帶子引導長度
LEAD TAPE LENGTH
出料方向
PULL OUT DIRECTEON

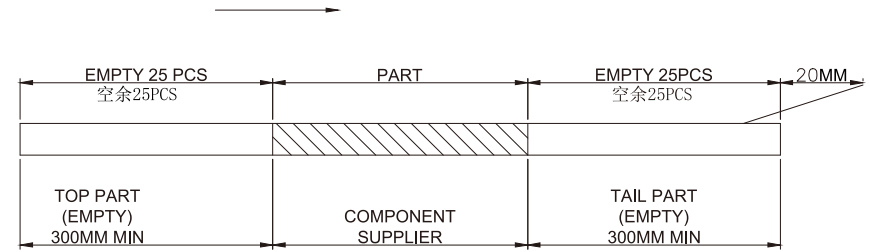

2. 出貨運輸過程中一定注意：
THIS REQUIREMENT SHOULD BE APPLIED AT SHIPMENT：
卷帶在運輸過程中不能散開
PEELING OFF SHOULD NOT BE ALLOWED DURING TRANSPORTATION

出料方向
PULL OUT DIRECTEON

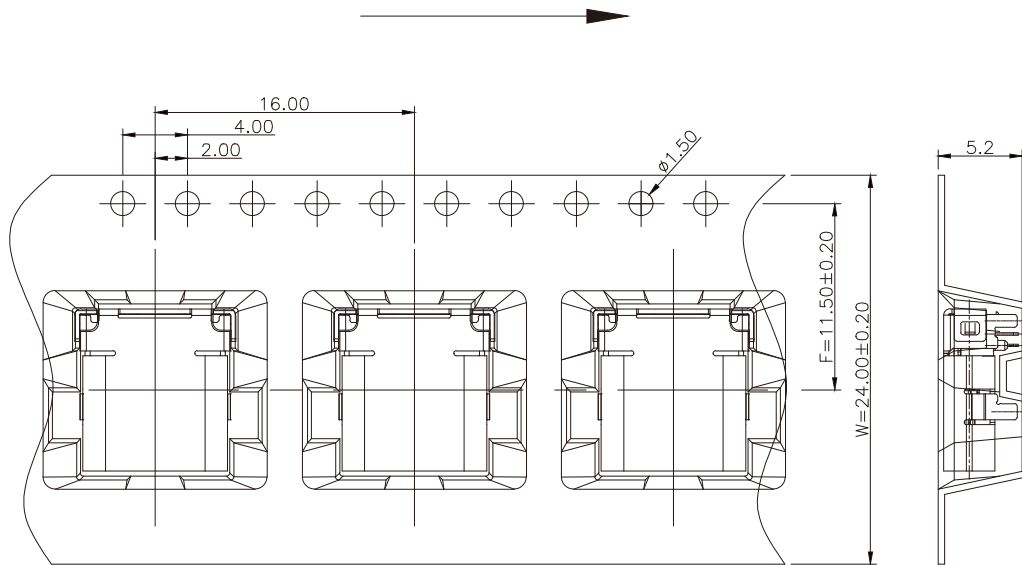
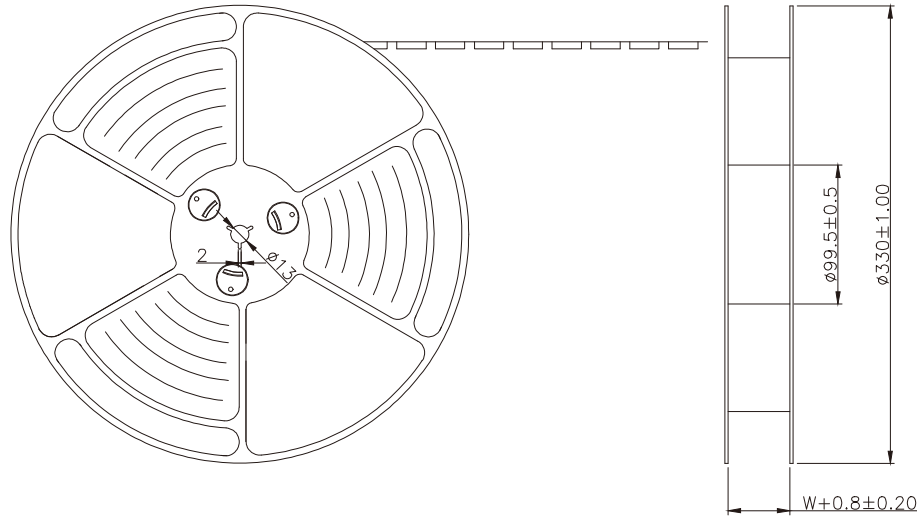

METRIC		WIROS Electronics Int'l CO., Ltd.	
DRAWER ZHUANG		NOTICE OF PROPRIETARY PROPERTY: THIS DRAWING CONTAINS INFORMATION THAT IS PROPRIETARY TO WIROS ELECTRONICS INTERNATIONAL COMPANY LIMITED. AND SHOULD NOT BE USED WITHOUT WIROS'S WRITTEN CONSENT.	
APPROVER ALEX, WU			
DIMENSIONS ARE IN MILLIMETERS TOLERANCES		TITLE	
X. ±0.50 X.X ±0.38 X.XX ±0.25 X.XXX ±0.10 ANGLES ±3°		USB 3.1 TYPE C 12P THT AND 12P SMT H=4.46mm, RECEPTACLE CONNECTOR	
DO NOT SCALE DRAWINGS		PRODUCT NUMBER	
THIRD ANGLE PROJECTION		RUCH1-1X×R024C3	
SIZE A4	REV.	SCALE 1 : 1	SHEET 3 OF 4

at small positioning hole of the carrier tape side).
 標籤黏貼處 (朝捲裝包材的小定位孔一側)
 Location of label sticking (label)

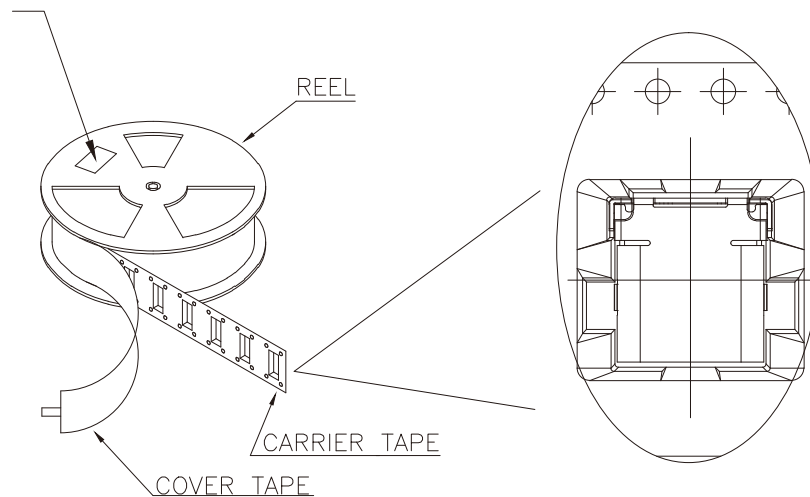
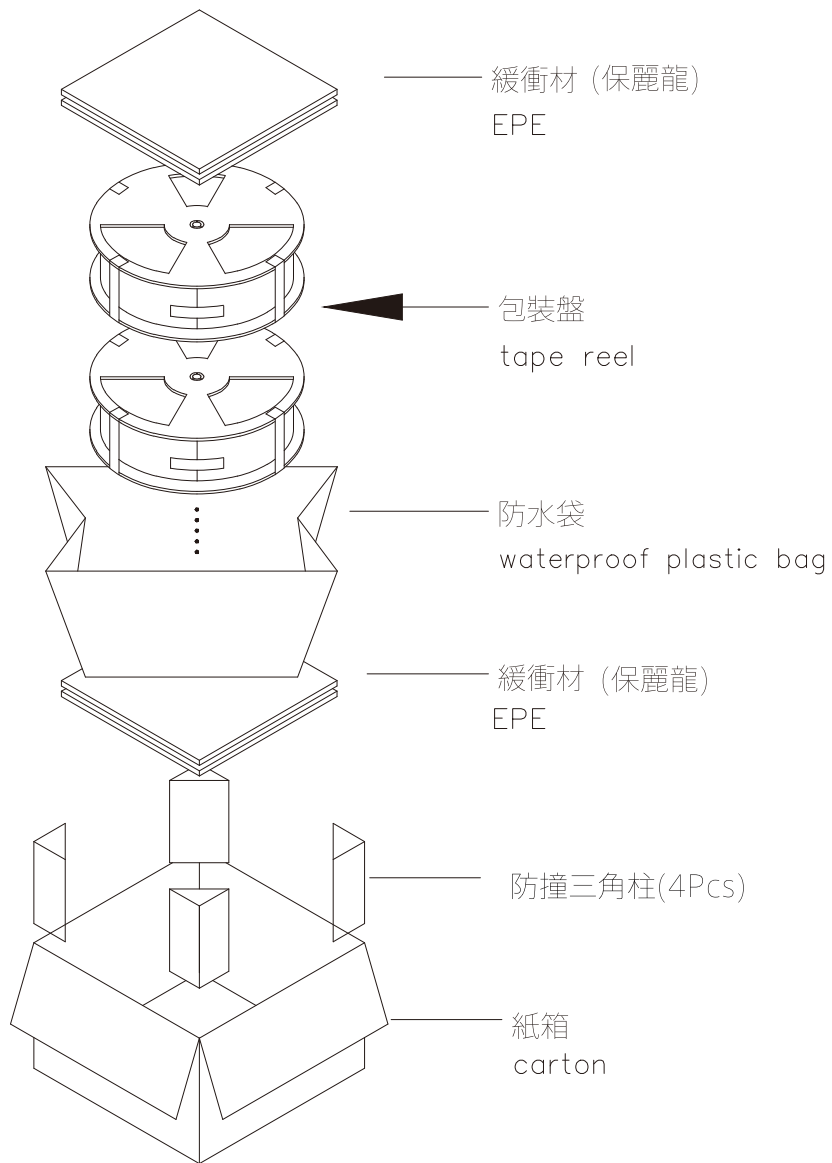

NOTE:

1. 捲包裝數量及箱裝箱數量如 左下表格。
Packing q'ty of each reel & carton as below table shown.
2. 以上膠帶覆蓋下包裝帶經包裝機熱熔包裝
Use cover tape to cover and hot melt machine to seal up.
3. 紙箱放2個珍珠棉
Every carton use 2pcs EPE.
4. 將裝滿事品的卷盤放入紙箱并以膠帶封口
Put reels in the carton and use adhesive tape to seal up.

PART NUMBER	PACKAGING QUANTITY		
	PCS/REEL	REELS/CARTON	PCS/CARTON
RUCH1-1xxR024C3	650	8	5,200

QUALITY CONTROL LINE DIMENSIONS SHALL MARKED THE SYMBOL AS ▲	METRIC		WIROS Electronics Int'l CO., Ltd.	
	DRAWER ZHUANG		NOTICE OF PROPRIETARY PROPERTY: THIS DRAWING CONTAINS INFORMATION THAT IS PROPRIETARY TO WIROS ELECTRONICS INTERNATIONAL COMPANY LIMITED. AND SHOULD NOT BE USED WITHOUT WIROS'S WRITTEN CONSENT.	
	APPROVER ALEX, WU			
	DIMENSIONS ARE IN MILLIMETERS TOLERANCES		TITLE	
<input checked="" type="checkbox"/> RoHS <input type="checkbox"/> HfP <input type="checkbox"/> HfP <input type="checkbox"/> LF	X. ±0.50 X.X ±0.38 X.XX ±0.25 X.XXX ±0.10 ANGLES ±3°	USB 3.1 TYPE C 12P THT AND 12P SMT H=4.46mm, RECEPTACLE CONNECTOR		
DO NOT SCALE DRAWINGS				
THIRD ANGLE PROJECTION		PRODUCT NUMBER RUCH1-1xxR024C3		
SIZE A4	REV.	SCALE 1 : 1	SHEET 4 OF 4	