

※NOTES※

MECHANICAL

- ① HOUSING : THERMOPLASTIC-LCP, UL94V-0, COLOR OPTIONAL
- ② CONTACT : COPPER ALLOY, PLATING OPTIONAL
- ③ SHIELD : COPPER ALLOY, 50μ NICKEL PLATING OVERALL

SPECIFICATION

- ① CURRENT RATING : 5 AMPHERES MIN. FOR VBUS
0.25 AMPERE MIN. FOR OTHERS
- ② VOLTAGE RATING : 5V AC MAX.
- ③ WITHSTANDING VOLTAGE : 100V AC
- ④ CONTACT RESISTANCE : 40mΩ MAX.
- ⑤ INSULATION RESISTANCE : 100MΩ MIN.
- ⑥ MATING/UNMATING FORCE : 5~20N. MAX.
- ⑦ DURABILITY : 10,000 CYCLES MIN.
- ⑧ SIGNALING RATE : 5 Gbps MIN.
- ⑨ OPERATION TEMPERATURE : -55°C ~ +85°C

PRODUCT ORDER OPTION

RUC09-1 * * * 024MA

PACKING METHOD
T~PLASTIC TRAY
F~VACUUM TUBE

PLATING
0~Au 0.2~1μ ON CONTACT AREA
2~Au 3μ ON CONTACT AREA
4~Au 15μ ON CONTACT AREA
6~Au 30μ ON CONTACT AREA

HOUSING COLOR
1~BLACK 2~BEIGE
A~BLUE 0~YELLOW

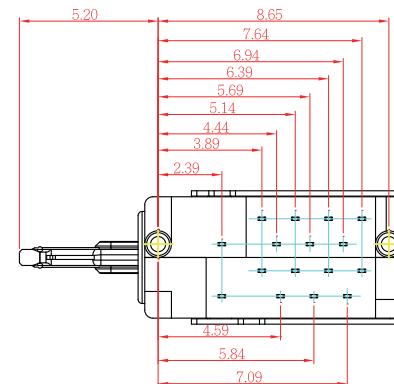
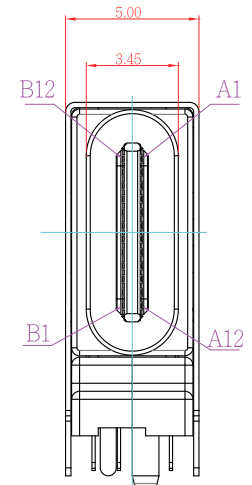
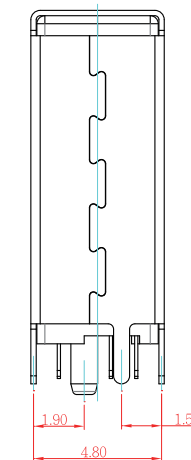
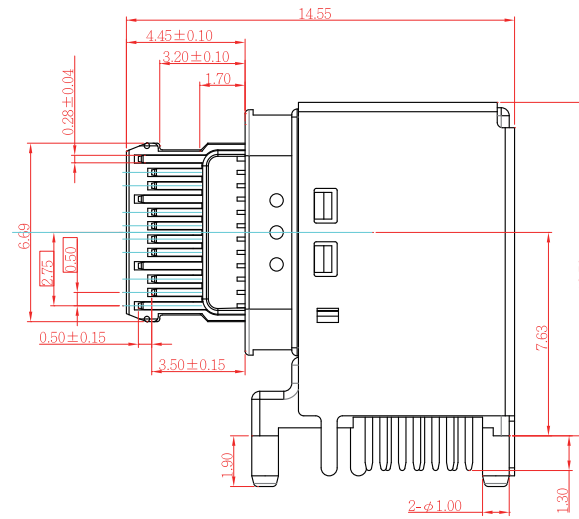
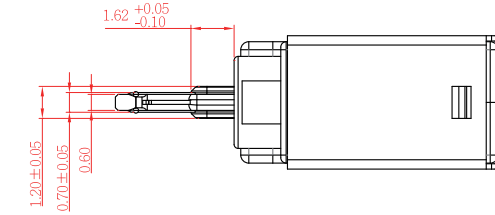

QUALITY CONTROL LINE DIMENSIONS SHALL BE MARKED THE SYMBOL IS *	METRIC		Wiros Electronics	
	DRAWER H. OZAWA		NOTICE OF PROPRIETARY PROPERTY: THIS DRAWING CONTAINS INFORMATION THAT IS PROPRIETARY TO WIROS ELECTRONICS INTERNATIONAL COMPANY LIMITED. AND SHOULD NOT BE USED WITHOUT WIROS'S WRITTEN CONSENT.	
	APPROVER Y. TOMITA		TITLE USB 3.1 TYPE C SIDE-ENTRY RECEPTACLE, THT	
	DIMENSIONS ARE IN MILLIMETERS TOLERANCES X. ±0.50 X.X ±0.38 X.XX ±0.25 X.XXX ±0.10 ANGLES ±5°		PRODUCT NUMBER RUC09-1**024MA	
DO NOT SCALE DRAWINGS THIRD ANGLE PROJECTION		SCALE NONE		
RoHS COMPLIANT HfP COMPLIANT LEAD FREE	SIZE A4	REV.	SHEET 1 OF 2	

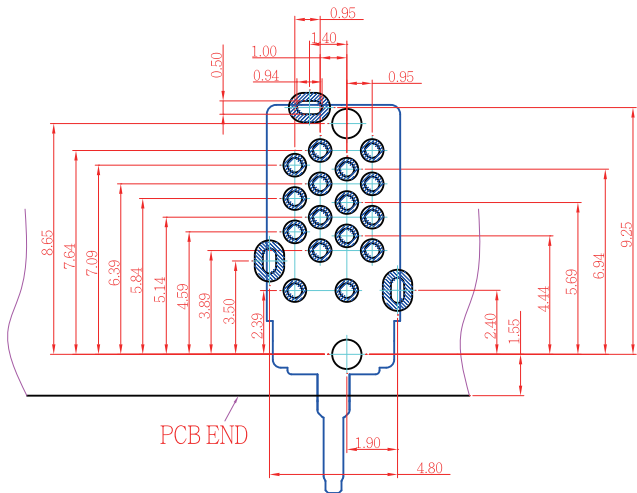
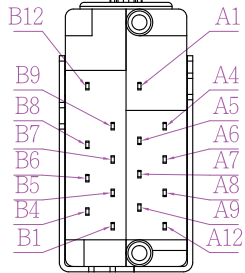
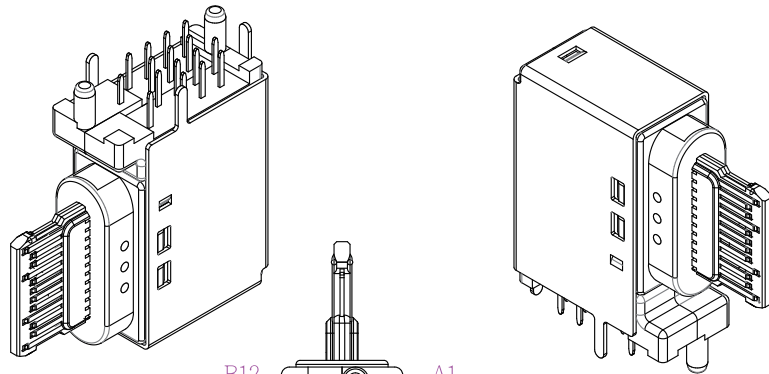

RECOMMEND P.C.B LAYOUT (THICKNESS=0.1mm)
(COMPONENT SIDE) TOLERANCE±0.02

USB TYPE-C FULL-FEATURED RECEPTACLE INTERFACE PIN ASSIGNMENTS

PIN	Signal Name	Description	PIN	Signal Name	Description
A1	GND	Ground return	B12	GND	Ground return
A2	SSTXp1	Positive half of first SuperSpeed TX differential pair	B11	SSRXp1	Positive half of first SuperSpeed RX differential pair
A3	SSTXn1	Negative half of first SuperSpeed TX differential pair	B10	SSRXn1	Negative half of first SuperSpeed RX differential pair
A4	VBUS	Bus Power	B9	VBUS	Bus Power
A5	CC1	Configuration Channel	B8	SBU2	Sideband Use (SBU)
A6	Dp1	Positive half of the USB 2.0 differential pair-Position 1	B7	Dn2	Negative half of the USB 2.0 differential pair-Position 2
A7	Dn1	Negative half of the USB 2.0 differential pair-Position 1	B6	Dp2	Positive half of the USB 2.0 differential pair-Position 2
A8	SBU1	Sideband Use (SBU)	B5	CC2	Configuraaation Channel
A9	VBUS	Bus Power	B4	VBUS	Bus Power
A10	SSRXn2	Negative half of second SuperSpeed RX differential pair	B3	SSTXn2	Negative half of second SuperSpeed TX differential pair
A11	SSRXp2	Positive half of second SuperSpeed RX differential pair	B2	SSTXp2	Positive half of second SuperSpeed TX differential pair
A12	GND	Ground return	B1	GND	Ground return

METRIC		Wiros Electronics	
DRAWER	H. OZAWA	NOTICE OF PROPRIETARY PROPERTY: THIS DRAWING CONTAINS INFORMATION THAT IS PROPRIETARY TO WIROS ELECTRONICS INTERNATIONAL COMPANY LIMITED. AND SHOULD NOT BE USED WITHOUT WIROS'S WRITTEN CONSENT.	
APPROVER	Y. TOMITA	TITLE	
DIMENSIONS ARE IN MILLIMETERS TOLERANCES		USB 3.1 TYPE C SIDE-ENTRY RECEPTACLE, THT	
X. ±0.50 X.X ±0.38 X.XX ±0.25 X.XXX ±0.10 ANGLES ±5°		PRODUCT NUMBER	
DO NOT SCALE DRAWINGS		RUC09-1**×024MA	
THIRD ANGLE PROJECTION		SCALE	
SIZE	A4	NONE	SHEET 2 OF 2